





giorno_ *pari & dispari*

comp_154

con struttura laccato opaco nero
frac, frontali *logic* battenti e schienali
componibili in finitura foglia oro.

with matt nero frac lacquered
structure, swing *logic* fronts and
modular back panels with a gold leaf
finish.

с матовым лакированным
каркасом цвета nero frac,
распашными лицевыми

When gold speaks,
eloquence is weak.

Когда говорит золото,
красноречие бессильно.

Quando l'oro parla, l'eloquenza è senza forza.

sta di uno
dà spazio
enti che si
del sole e
ella verità.
ne, gioioso
atterizza il
a zona più
della casa.

Points of view of a
minimalist style that leaves
space for clever items that
take on the shades of the
sun and of truth. A young,
joyful and carefree style
marks the lifestyle of the
most public area of the
house.

Точки зрения на
строгий стиль жизни,
предоставляющий место
мудрому присутствию,
окрашивающемуся в цвет
солнца и правды.
Молодежный, игривый
и непринужденный
стиль характеризует
образ жизни в самой
“общественной” части
дома.









giorno_ *oasi*

comp_122

con schienali boiserie in finitura
foglia oro, basi e mensole
in laccato lucido nero frac.

with gold leaf finish back panels,
gloss nero frac lacquered wall units
and shelves.

с задними стеновыми
панелями, отделанными
золотой фольгой, основания и
полки с глянцевой лакировкой
цвета nero frac.





Eric Segal

There are never too many clocks, but
there is always too little time.

Часов никогда не бывает много, а
времени всегда мало.

*G*li orologi
non sono
mai troppi,
ma il tempo
è sempre
troppo poco.







sirio con piano in vetro
colorato nero frac.
comò *globo_2*
in finitura foglia oro.

headboard upholstered
with *cocometal* fabric, *sirio*
coffee tables with nero frac
lacquered glass top.
globo_2 gold leaf
finish dresser.

спинкой из
cocometal, сто
столешнице
цвета nero f
комод *g*
с отделкой з
фольгой.





Eleanor Roosevelt

the future belongs to those who believe
in the beauty of their dreams.

будущее принадлежит тем, кто
верит в красоту своих мечтаний.

Il futuro appartiene
crede nella bellezza
dei propri sogni.











con struttura e frontali
in finitura foglia oro.

globo_2 dresser with gold
leaf finish structure and

комод *globo_2*
лицевыми панелями

notte







pent from their
et their love.

которые одумываются о
ных поступках, сожалеют
и

e che si ravvedono follie si pentono more.

nte e satinato,
mporre
uce in una
pagliori:
bili e cose di
ur, fascinosa
ora.
portante, forse
vato a case per
na, o eccentrici
vediamo
teria prima
ziose alchimie

Smooth, shiny and
satinated, or designed to break
each ray of light down into
a multitude of flashes: gold
coats furniture and things
with an allure of glamour, as
fascinating today as it was in
the past.

An important colour,
perhaps once reserved to
the homes of film stars or of
eccentric aristocrats, it now
becomes the main ingredient
for endless, precious furniture
for endless, precious furniture
alchemies.

Гладкое, блестящее и
сатинированное или же
обработанное так, чтобы
дробить любой луч света
на множество отблесков.
Золото облачает мебель
и вещи в гламурный
аллюр, столь же
обворожительный сейчас,
как и раньше.

Важный цвет, который
когда-то предназначался
лишь только для
домов кинозвезд
или эксцентричных







Walter Bagehot

It is good to be without vices it is bad
to be without temptations.

Хорошо не иметь пороков,
плохо не иметь соблазнов.

bene non avere vizi
non avere tentazioni.







notte_ *tecnopolis*

con ante scorrevoli liscie laccate
lucido bianco candido e ante *luxury*
con specchio e cornice scolpita in
finitura foglia oro.

*tecnopolis*_bedroom furniture
with gloss bianco candido lacquered
plain sliding doors and *luxury* doors
with mirror and gold leaf finish
sculptured frame.

спальня_ *tecnopolis*
с глянцевыми, лакированными,
гладкими створками цвета
bianco candido и створками
luxury с зеркалом и резной
рамкой с отделкой золотой
фольгой.



inde
SIZE

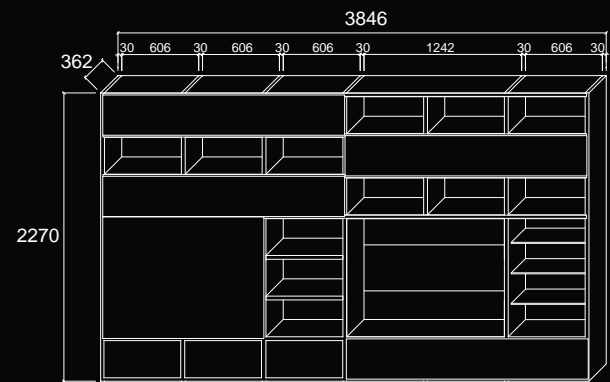

pari & disp
pag42_45

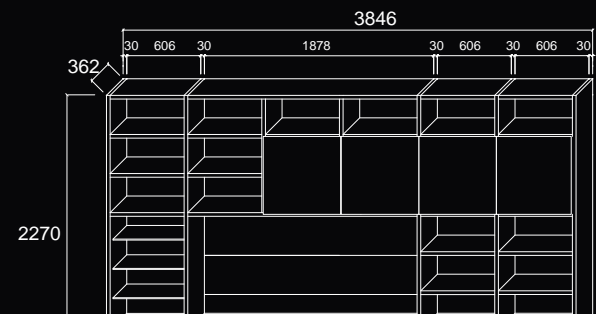
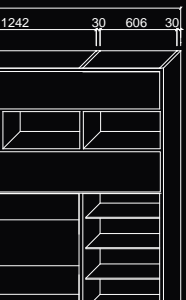

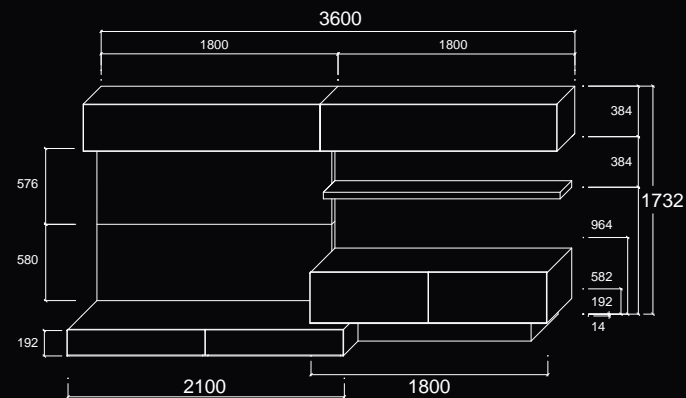

oasi comp_

pag84_87

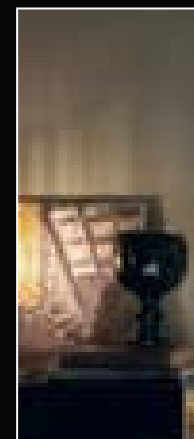
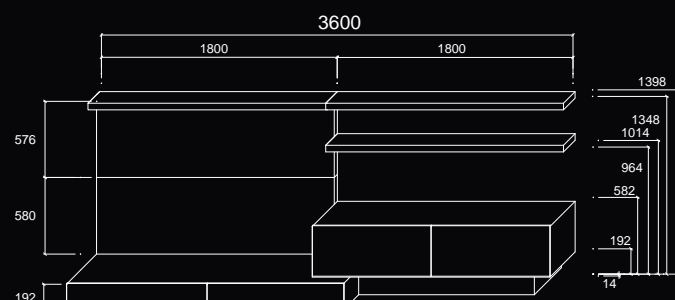
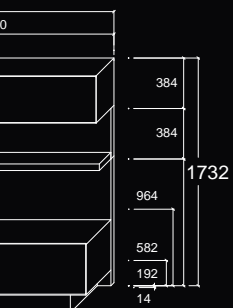

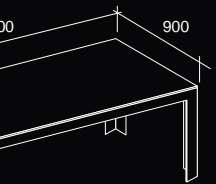

tavolo_star

pag8_13

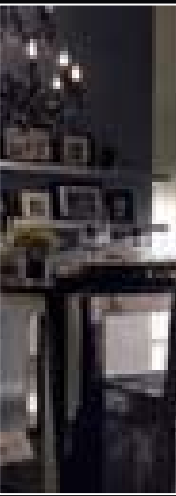
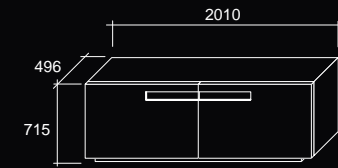

madia_mod

pag10_15

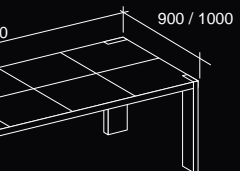

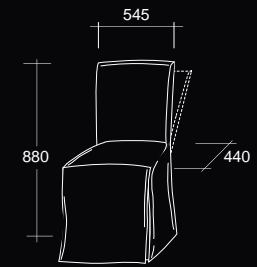

sedia_iris

pag8_13 | 16_17

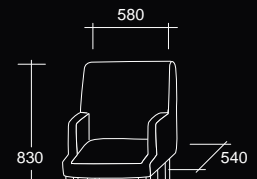
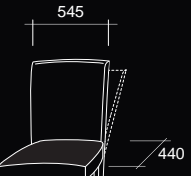

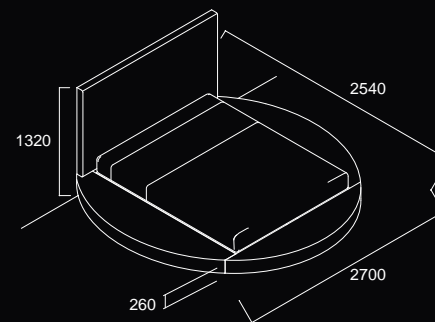

letto_ **zero**

pag96_101

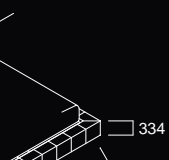
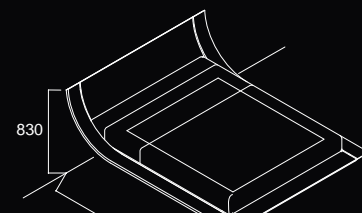

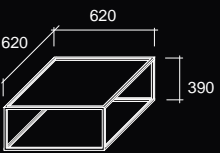

notte_tavolino_eolo

pag54_57

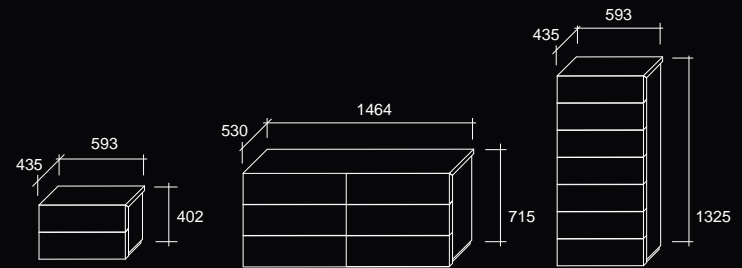

notte_grupp

pag48_49 | 50_51

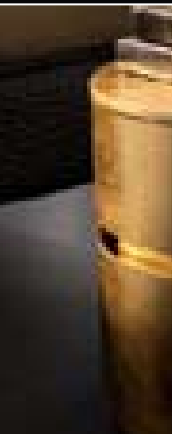

H. 2256
H. 2384
H. 2576

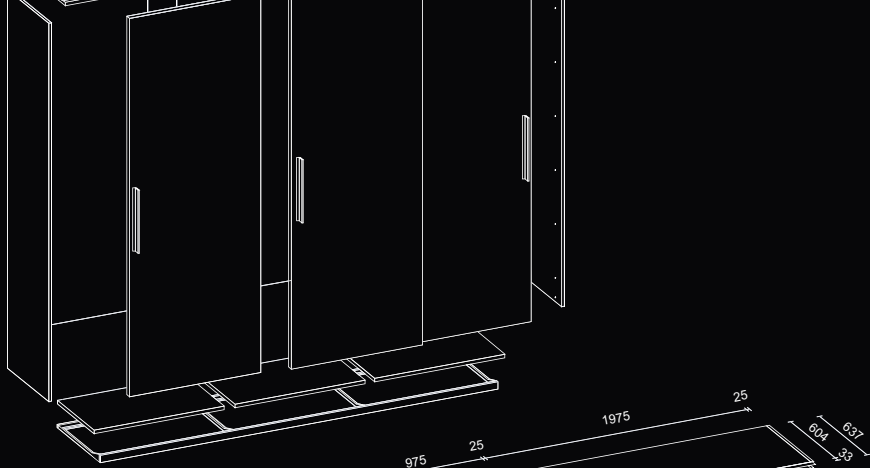

2576

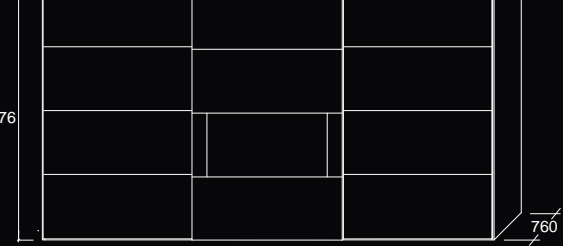

armadio_t

pag58_63

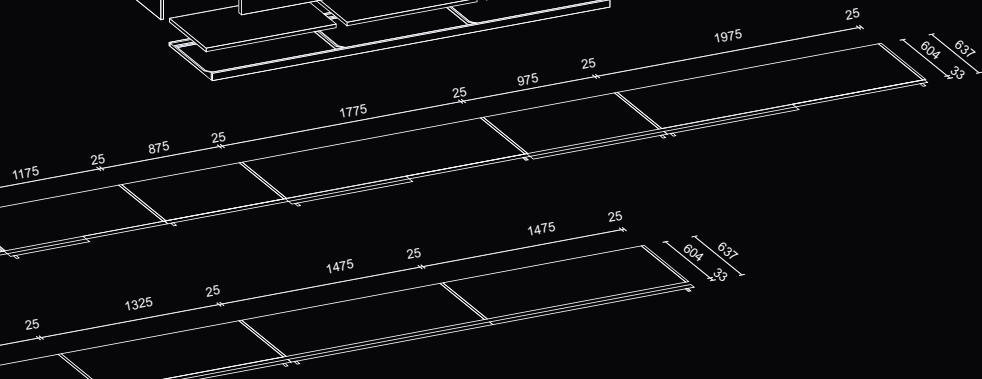

2576

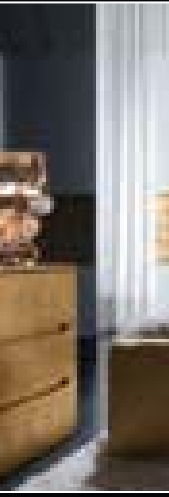
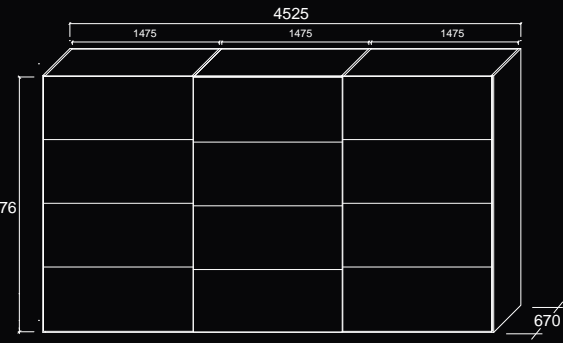

armadio_t

pag120_123

H. 2256
H. 2384
H. 2576
H. 2896

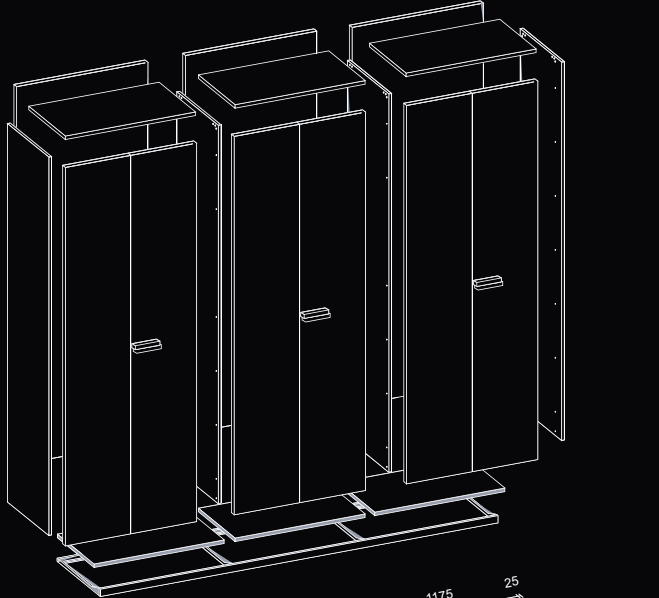

2576

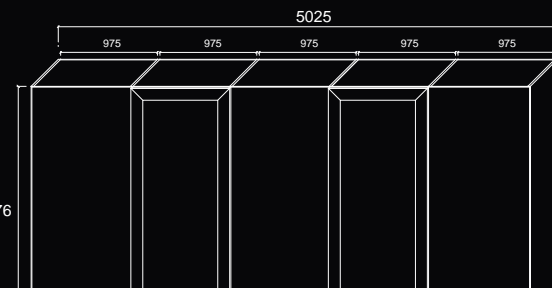



art direction:
pierangelo sciuto
graphic design:
fulvio serasin
ricerca, sviluppo
& marketing:
presotto italia

photo:
F2 fotografia
styling:
Laura Comiotto
color separation:
gfp.it
printed in italy by
gfp.it

si ringrazia:
lampade:
www.adrianalohmann.com
oggetti:
artestudio - como,
ilion - milano,
mesa - bregnano,
quadri:
pulkra - como
sculture:
elena minotti - meda
biancheria letti:
papi homewear
by danmor,
cavenago di Brianza
tappeti: ligne pure by dal santo,
www.floorcovering.it
cornici:
italianframingart meda

3 PRESOTTO
T A L T A

collezioni *folies* gennaio2008

Azienda con sistema di gestione
ambientale conforme al Regolamento
Europeo EMAS

A company with an environmental
management system complying with the
EMAS European Regulations.



Azienda con certificazione del sistema
di gestione ambientale e della salute
e sicurezza sui luoghi di lavoro.

Company using a certified environment
and health and safety on the workplace
management system.



Copyright © 2008 Presotto Italia

tutti i diritti sono riservati.

è vietata la riproduzione
sotto forma di stampa, fotocopia,
microfilm, o qualsiasi altro sistema,
senza il permesso scritto
della società autrice.

all rights reserved.

no part of this catalogue
may be reproduced in any form
by print, photocopy, microfilm,
recording or any other means
without the prior written
permission of the publishers.

presotto Industrie mobili spa via puja, 7 - frazione maron 33070 brugniera (pn) italy
tel +39 0434 618111 fax +39 0434 613558 pr_info@presotto.com www.presottoitalia.it

